

TIN KNOCKER

TK NO. 30 CLEAT BENDER

INSTRUCTIONS & PARTS DIAGRAM



Shown with Optional Stand

TAAG INDUSTRIES CORP.
1550 SIMPSON WAY, ESCONDIDO, CA 92029
Tel: (800) 640-0746 Fax: (760) 727-9948
Website: www.tinknocker.com Email: info@taagind.com

**TIN KNOCKER
SAFETY RULES
TK NO. 30 CLEAT BENDER**

1. Never use a machine or tool for anything other than its intended purpose. Use the proper tool and equipment for the task.

2. Do not operate the machine in excess of its rated capacity.

WARRANTY

All new machines are sold with a one-year limited warranty, on factory defective parts. The warranty is limited to the original user. TAAG Machinery Co. at its option, will repair, replace or refund the purchase price of any part, tool or machine that fails during the warranty period. TAAG Machinery Co. will pay normal shipping charges for replacement parts. After 90 days from date of purchase, all express or overnight delivery charges are the responsibility of the customer. Purchaser must deliver to TAAG Machinery Co., at the address below, any written claim, with proof of original purchase. Replacement parts will be invoiced to purchaser and credit issued when the failed part is delivered to TAAG Machinery Co. Removal, reinstallation or replacement parts shall be at purchasers' / user's expense. Failure due to improper use of the machine voids the warranty.

NOTE: 1. This machine has been tested and adjusted prior to shipment, but can and often does require readjustment due to vibration and bouncing during transport. Following the procedures described within can easily do readjustment. These are procedures with which you, as a user, should be familiar, as you will use them repeatedly over the life use of the machine. If you have difficulty in performing these procedures, we are here to support you. Call us at: (800) 640-0746.

2. Opening rolls (for Philipsburg Lock) are consumable items and not subject to warranty.

**TAAG INDUSTRIES CORP.
“The Tin Knocker People”
1550 SIMPSON WAY, ESCONDIDO, CA 92029
Tel: (800) 640-0746 Fax: (760) 727-9948
Website: www.tinknocker.com Email: info@taagind.com**

TK No. 30 CLEAT BENDER,

RECEIVING THE MACHINE Inspect before signing Bill of Lading.

Upon receipt closely examine the cleat bender for damage during shipment. Be certain you have two handles. Any loss or damage should be noted in detail on the delivery receipt and reported to your distributor immediately. Free replacement from TK International is dependant upon the notation and the Bill of Lading on delivery slip.

INSTALLING THE MACHINE

Locate the cleat bender in a well-lighted area on a solid, level floor. The cleat bender must be securely bolted to a bench or TK manufactured optional stand. The workbench or stand must be securely mounted to the floor.

By positioning the cleat bender at the end of the worktable it is possible to bend drive cleat edges on rectangular ductwork of substantial size. Examine your clearances before bolting the machine to the bench. Be sure you have adequate room to swing both handles.

PRECAUTIONS

DO NOT use the cleat bender to bend rods, nails or wires. This will cause damage to the edge of the top blade. DO NOT exceed the capacity of the cleat bender, which is 20 gauge (0.036 inches) mild steel.

OPERATING THE MACHINE

The segmented base of your cleat bender is designed so that duct sections and fittings of almost every dimension will fit into the bender with one or both legs formed to right angles. Your duct or fittings should be notched at the corners to properly form your drive cleat pocket. Recommended notch depth is 7/16 to 1/2 inch. Recommended notch angles are 30 to 45 degrees. Insert your notched duct flange under the upper blade of the cleat bender. Raise the top handle to its complete arc point, approximately 150 degrees. Leave the top handle in this position and release the lower handle by depressing the latch and raising the handle at the same time. Raise the lower handle to its complete arc point. At this time push the duct section into the throat of the cleat bender to release the formed drive cleat flange. When released, withdraw the duct section from the tool. Return both handles to their normal down position. If desired, the top leaf of the cleat bender can now be used to close the drive cleat edge to +180 degrees. Your drive cleat edge is now complete.

Your cleat bender can also be used to make actual drive cleats used in joining duct sections together. Your drive cleat blanks should be sheared or slit into appropriate width: approximately 2 1/8 inches. The bending procedure is the same as for drive cleat edges on ducting with the exception that the lower handle does not have to be released to remove the cleat after each bend. Use the top leaf of the cleat bender to close the drive cleat edge to 180 degrees.

SPECIFICATIONS:

Capacity: 20 Ga. Mild steel x 30" (1/2" DEPTH)

Dimensions: Approx. 38" x 10" x 11 1/2" (126 lbs.)

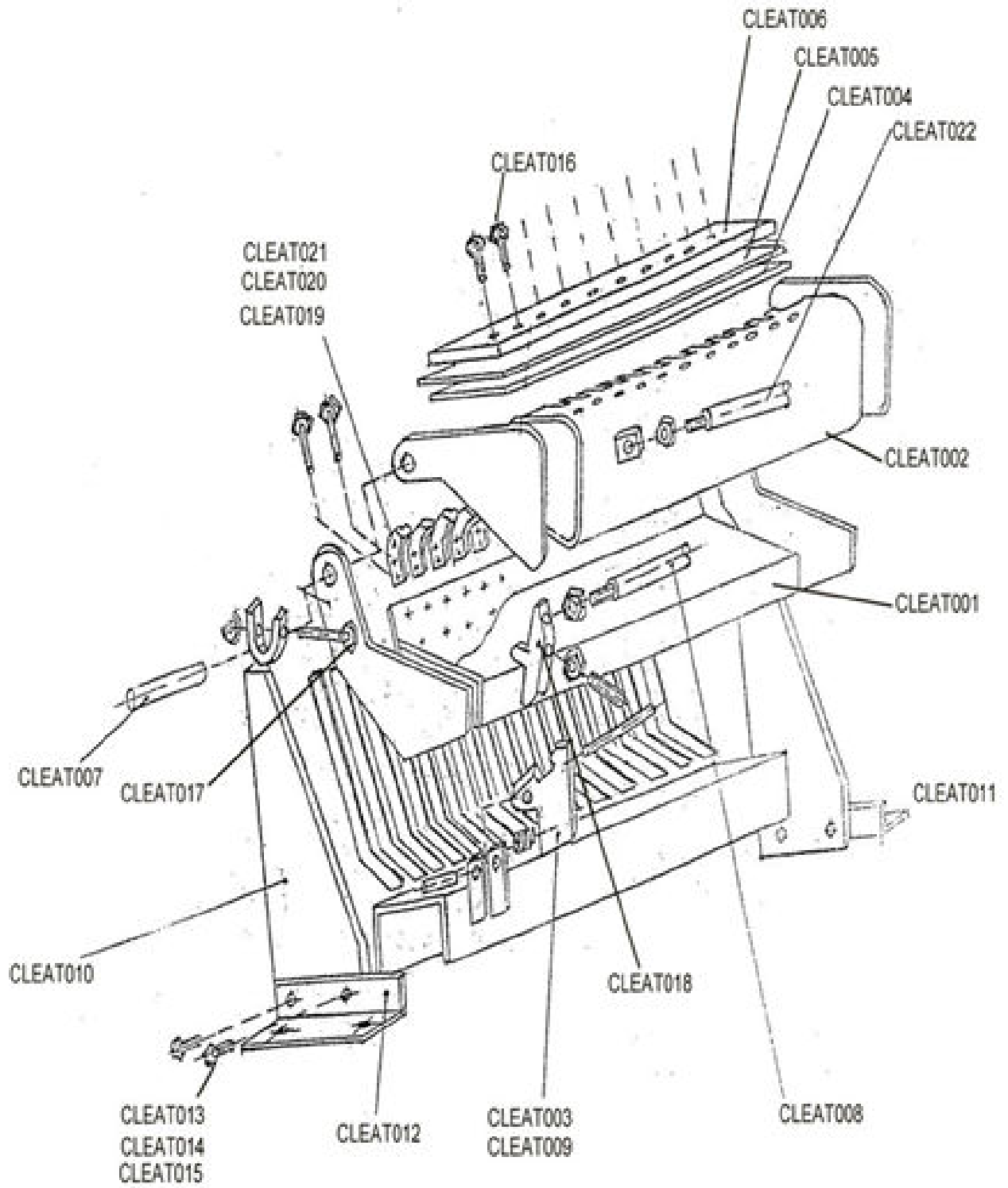

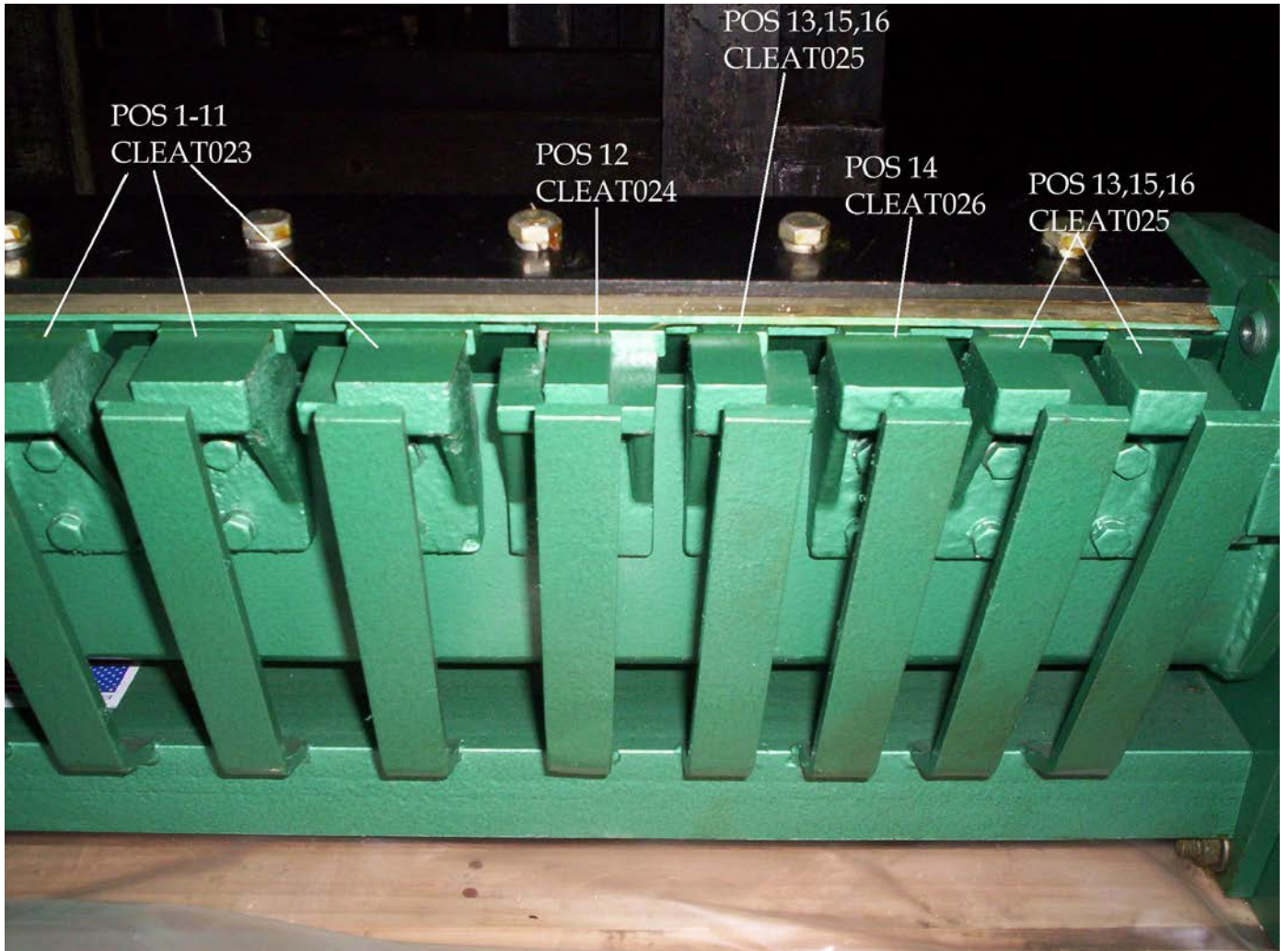

Parts For No. 30 Cleat Bender

Fine No.	Part No.	Description	No. REQ"D.
1	CLEAT001	Bottom Leaf	1
2	CLEAT002	Top Leaf	1
3	CLEAT003	Latch	1
4	CLEAT004	Spacer, Top	1
5	CLEAT005	Blade, Top	1
6	CLEAT006	Hold down Plate	1
7	CLEAT007	Pin, Hinge	2
8	CLEAT008	Handle	1
9	CLEAT009	Spring, Latch	1
10	CLEAT010	Frame Assembly	1

11	CLEAT011	Brkt., Right Hand Stand	1
12	CLEAT012	Brkt., Left Hand Stand	1
13	CLEAT013	Screw Stand, Brkt.	4
14	CLEAT014	Lock Washer, Brkt.	4
15	CLEAT015	Nut, Brkt. Screw	4
16	CLEAT016	Screw, Hold down	1
17	CLEAT017	Screw, Hinge Brkt.	2
18	CLEAT018	Stop Pin, Hinge Brkt.	1
19	CLEAT019	Fingers	
20	CLEAT020	Bolt, fingers	32
21	CLEAT021	Lock Washer,	32
22	CLEAT022	Handle	1
23	CLEAT023	FINGERS (POS 1-11)	11
24	CLEAT024	FINGERS (POS 12)	1
25	CLEAT025	FINGERS (POS 13,15,16)	3
26	CLEAT026	FINGERS (POS 14)	1